

1. CUT HOLE IN PLASTERBOARD AS PER DIMENSIONS SHOWN.
2. IF USING MULTIPLE LENGTHS OF EXTRUSION, SLIDE EXTRUSIONS TOGETHER ON TO JOINER OR BEND PLATE AND LOCK TOGETHER USING GRUB SCREWS PROVIDED.
3. IF USING SEISMIC RESTRAINT BRACKETS, SLIDE INTO EXTRUSION AND LOCK USING GRUB SCREW PROVIDED. SECURELY FASTEN USING WIRE CABLE (NOT SUPPLIED).
4. FIX END CAPS TO EXTRUSION USING 3.5X10MM CSK SCREWS PROVIDED.
5. DRILL A 9.5MMØ HOLE IN EXTRUSION FOR ELECTRICAL CABLE.
6. DRILL 5MMØ HOLES IN EXTRUSION FOR MOUNTING BRACKETS (SEE FIG. 1 AND NOTE BELOW). INSERT M5X30 CSK SCREWS AND SCREW INTO MOUNTING BRACKETS. JUST FAR ENOUGH TO FIT M5 CAP NUTS. TIGHTLY SCREW ON M5 CAP NUTS. MOUNTING BRACKETS SHOULD BE NO MORE THAN 800MM APART AND SHOULD BE WITHIN 200MM OF AN END OR JOIN.

7. PUSH LIGHT ASSEMBLY INTO PLASTERBOARD HOLE, ENSURING MOUNTING BRACKETS ARE RESTING FLAT AGAINST SIDE OF EXTRUSION. GENTLY TIGHTEN M5 SCREWS - MOUNTING BRACKETS WILL AUTOMATICALLY SPIN AND GRIP PLASTERBOARD. DO NOT OVERTIGHTEN TO PREVENT DAMAGE TO PLASTERBOARD.

NOTE: MOUNTING HOLES FOR BRACKETS MUST BE DRILLED A MAXIMUM OF 800MM APART AND MUST BE DRILLED WITHIN 200MM OF EACH END OF THE EXTRUSION AND WITHIN 200MM EITHER SIDE OF A JOIN OR BEND.

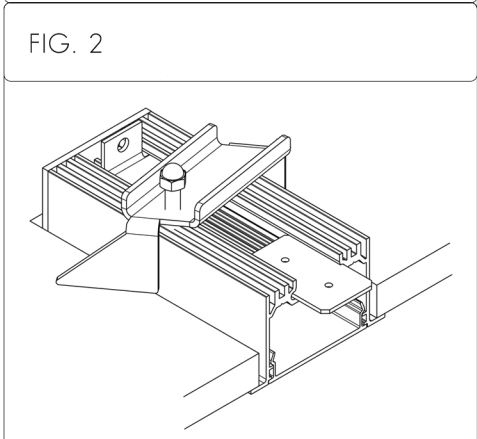
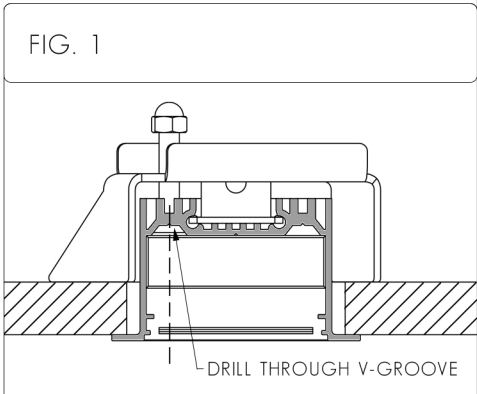

3 CLEAN EXTRUSION, INSTALL LED STRIP AND DIFFUSER.

1. MAKE ELECTRICAL CONNECTION: CONNECT LED STRIP TAILS TO LED DRIVER.
2. FEED LED STRIP TAILS (OR CABLE) THROUGH HOLE IN EXTRUSION AND CLAMP USING CORD GRIP SUPPLIED.
3. **IMPORTANT:** BEFORE MOUNTING LED STRIP, CLEAN EXTRUSION USING AN ALCOHOL BASED CLEANER.
4. REMOVE BACKING FROM LED STRIP TO EXPOSE STICKY SURFACE. LAY LED STRIP INTO EXTRUSION. USE A DAB OF SILICON AT EACH END OF THE LED STRIP TO PREVENT ENDS FROM LIFTING OFF EXTRUSION.
5. CLIP DIFFUSER INTO EXTRUSION, ENSURING A FIRM CONNECTION (SEE FIG. 3).

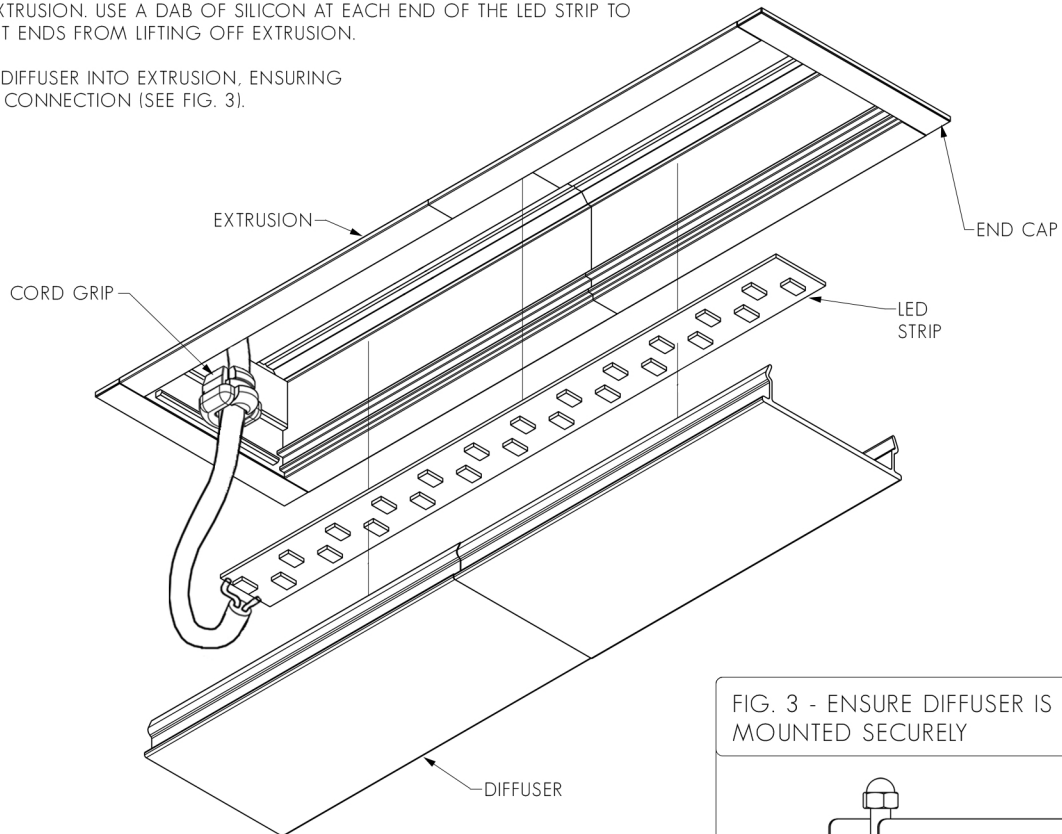

FIG. 3 - ENSURE DIFFUSER IS MOUNTED SECURELY

