

1 PRODUCT OVERVIEW

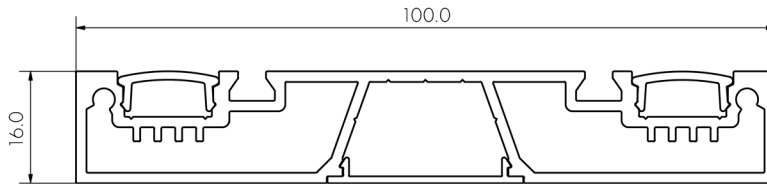

SWEET 16

2 JOIN EXTRUSIONS, ASSEMBLE ROD SUSPENSION

1. IF USING MULTIPLE LENGTHS OF EXTRUSION, SLIDE EXTRUSIONS TOGETHER ON TO JOINER OR BEND PLATES AND TIGHTEN GRUB SCREWS (SEE FIG. 1).
2. SLIDE 'SUSPENSION BRACKET' INTO GROOVES IN TOP OF EXTRUSION.
3. TIGHTEN GRUB SCREWS IN 'SUSPENSION BRACKET' TO LOCK BRACKET IN PLACE. BE SURE NOT TO OVER TIGHTEN.
4. SCREW 'ROD SUSPENSION' IN TO 'SUSPENSION BRACKET' AND TIGHTEN (SEE FIG. 2).

FIG. 1 - TIGHTEN SCREWS IN JOINER/BEND PLATES

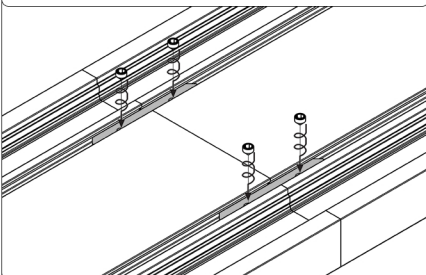
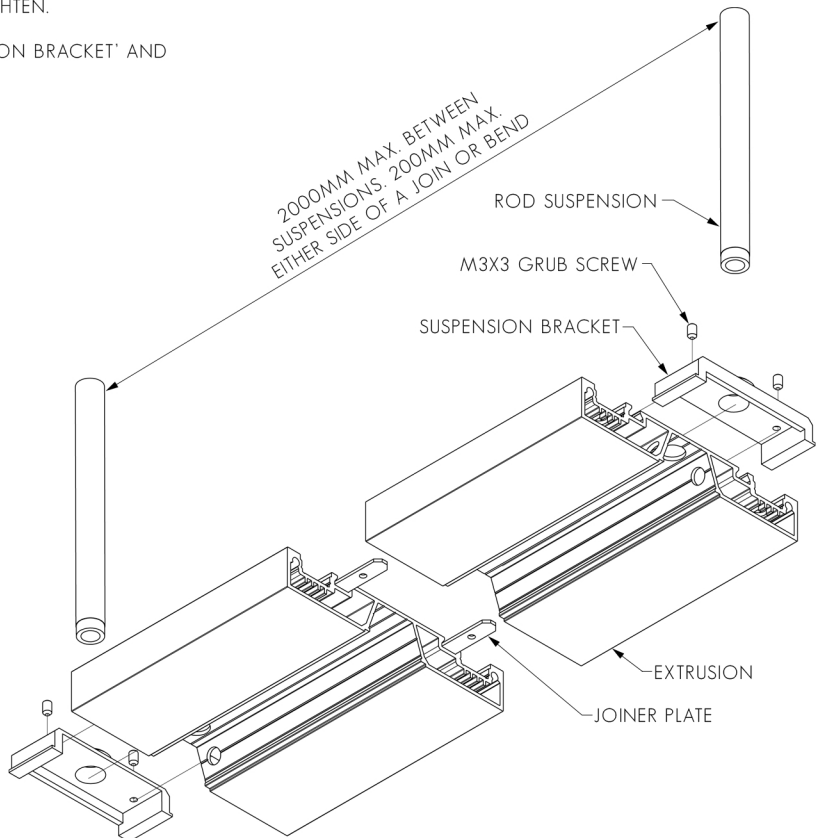
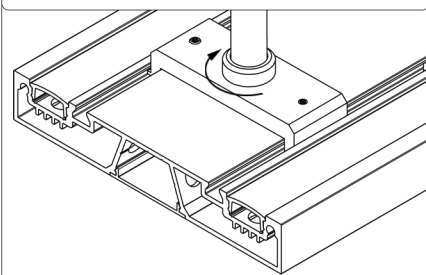

FIG. 2 - ENSURE ROD SUSPENSION IS SCREWED TIGHTLY.



NOTE: ROD SUSPENSIONS MUST BE LOCATED WITHIN 200MM FROM EACH END AND WITHIN 200MM EITHER SIDE OF A JOIN OR BEND. E.G. A 2500MM EXTRUSION SHOULD HAVE 3 MOUNTING POINTS, ONE CENTRED AND ONE EACH END WITHIN 200MM.

**3** FEED CABLE THROUGH ROD SUSPENSION, CLEAN EXTRUSION, INSTALL LED STRIP, DIFFUSER AND END CAPS

1. FEED LED STRIP TAILS (OR CABLE) THROUGH ROD SUSPENSION AND DOWN INTO EXTRUSION (SEE FIG. 3).
2. **IMPORTANT:** BEFORE MOUNTING LED STRIP, CLEAN EXTRUSION USING AN ALCOHOL BASED CLEANER.
3. REMOVE BACKING FROM LED STRIP TO EXPOSE STICKY SURFACE. LAY LED STRIP INTO EXTRUSION, USING THE SMALL GROOVES IN THE BACK OF THE EXTRUSION AS A GUIDE.
4. CLIP DIFFUSER INTO EXTRUSION, ENSURING A FIRM CONNECTION (SEE FIG. 4).
5. SLIDE END CAPS INTO ENDS OF EXTRUSION.

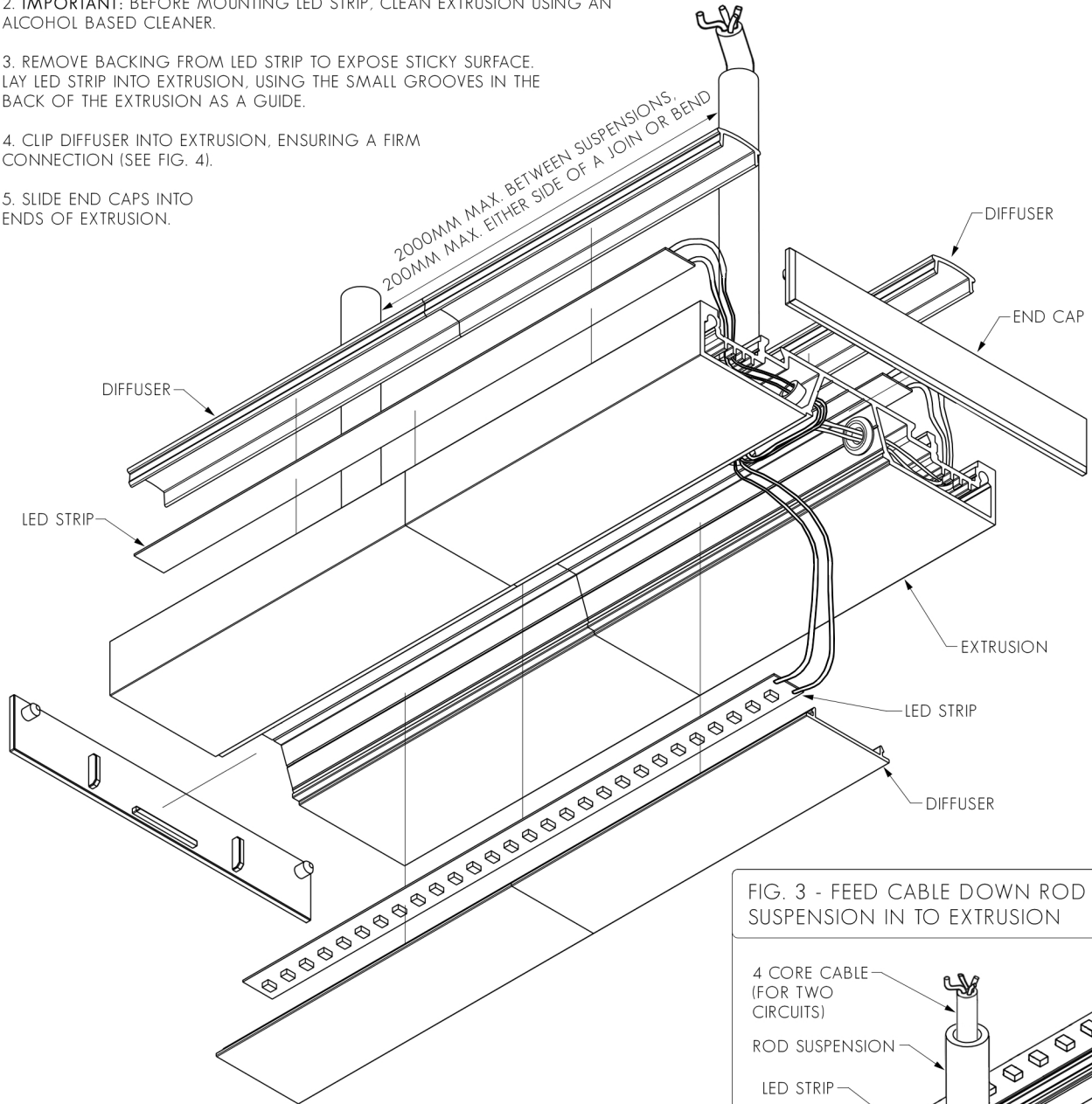

FIG. 3 - FEED CABLE DOWN ROD SUSPENSION IN TO EXTRUSION

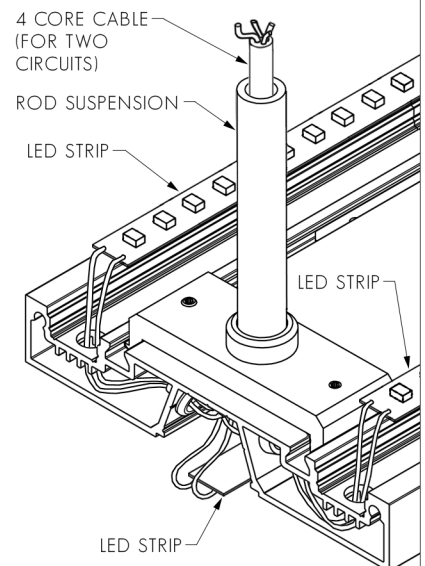
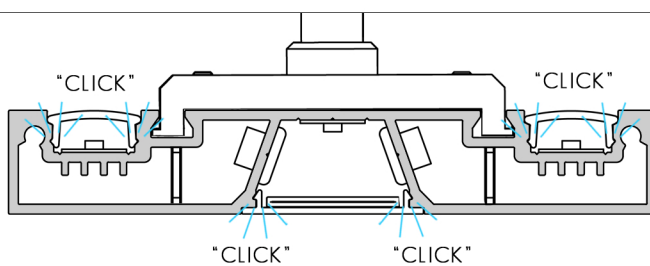

FIG. 4 - ENSURE DIFFUSERS ARE MOUNTED SECURELY



**4** ATTACH CEILING BRACKETS, HANG SUSPENSION RODS, MAKE ELECTRICAL CONNECTION, INSTALL CABLE BASE, CLEAN EXTRUSION, INSTALL LED STRIP, DIFFUSER AND END CAPS

1. LIFT LIGHT ASSEMBLY UP TO CEILING AND MARK LOCATIONS OF RODS ON CEILING. USE MARKINGS TO CUT 47-48MMØ HOLES FOR CABLE BASES (RECESSED VERSION ONLY - SEE FIG. 5 FOR SURFACE MOUNTED VERSION).

2. SCREW CEILING BRACKETS INTO FRAMING BEHIND PLASTERBOARD.

3. MAKE ELECTRICAL CONNECTION: CONNECT LED STRIP TAILS TO LED DRIVER USING CRIMP CONNECTORS, THEN SEAL WITH HEAT SHRINK.

4. LIFT LIGHT ASSEMBLY AND INSERT SUSPENSION RODS INTO CEILING BRACKETS, STARTING WITH THE POWER SUPPLY END. ADJUST REMAINING ROD SUSPENSION POSITIONS BY LOOSENING COLLARS AND REPOSITIONING. LOCK IN TO PLACE BY TIGHTENING GRUB SCREW ON ONE SIDE AND HEX HEAD SCREW ON OTHER SIDE, ENSURING HEX HEAD SCREW FITS THROUGH 4MMØ HOLE IN SUSPENSION ROD. (SEE FIG. 6)

5. PUSH CABLE BASE INTO HOLE IN CEILING (SEE FIG. 7).

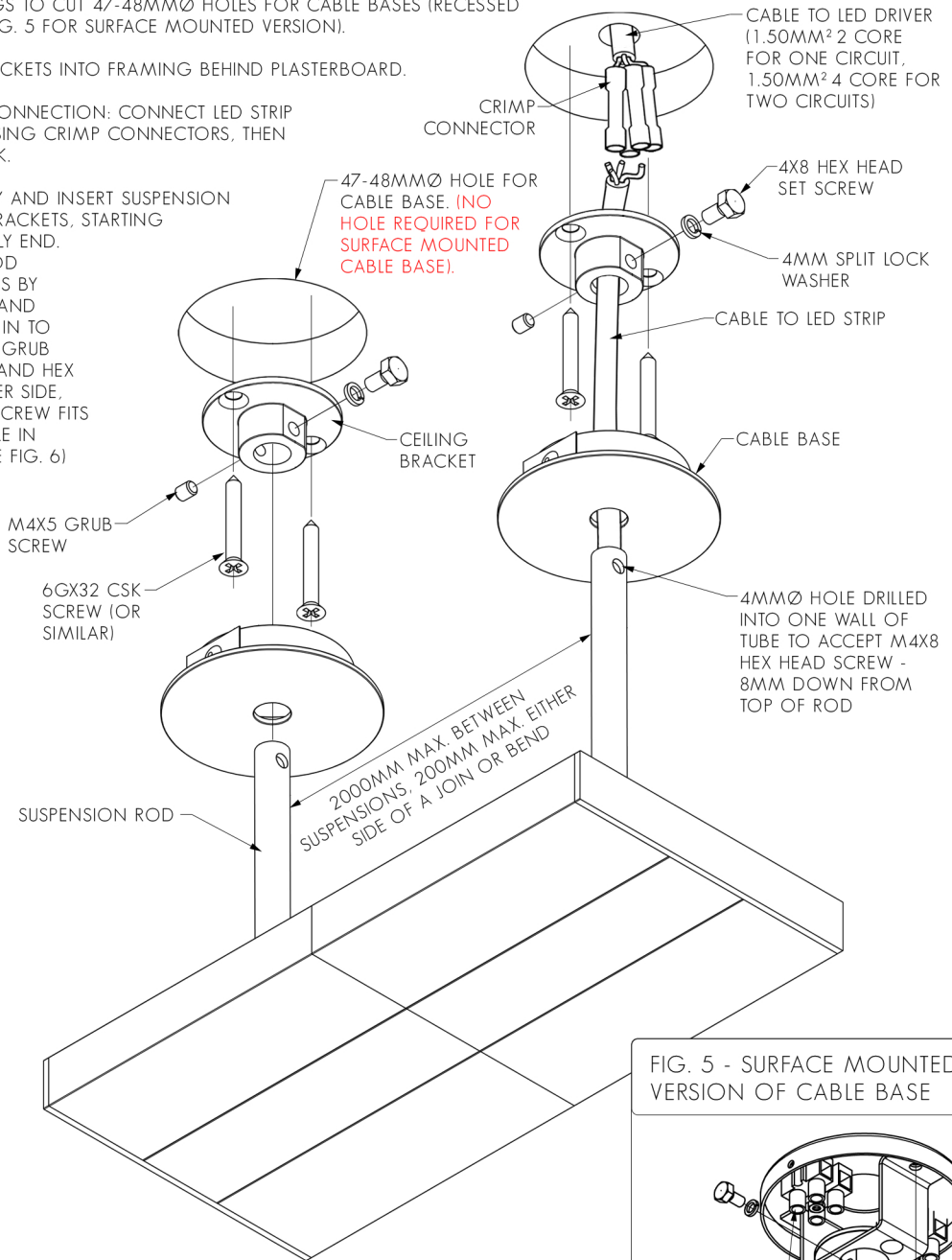

FIG. 5 - SURFACE MOUNTED VERSION OF CABLE BASE

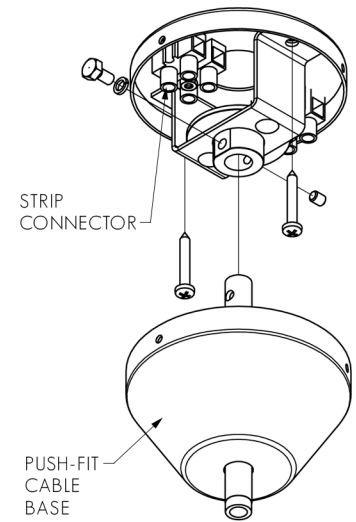

FIG. 6 - ENSURE SUSPENSION RODS ARE TIGHTLY SECURED

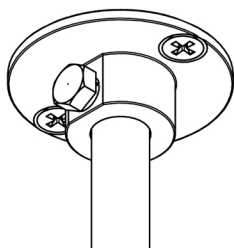

FIG. 7 - INSERT CABLE BASE IN TO CEILING

ANGLE CABLE UP TO HOLE, USING THUMBS TO COMPRESS SPRING CLIP ON ONE SIDE.

