

1 PRODUCT OVERVIEW

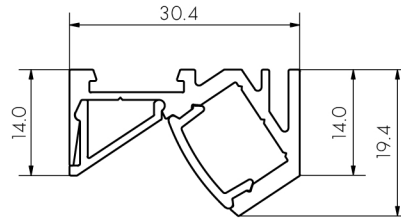

WHERE'S BEN 14

2 SCREW-FIX EXTRUSION.

1. DRILL Ø4MM - Ø4.5MM MOUNTING HOLES IN EXTRUSION.

NOTE: MAXIMUM SPACE BETWEEN MOUNTING HOLES SHOULD BE 400MM. MOUNTING HOLES MUST BE DRILLED WITHIN 100MM OF EACH END AND WITHIN 100MM EITHER SIDE OF A JOIN OR BEND. E.G. A 1000MM EXTRUSION SHOULD HAVE 3 MOUNTING POINTS, ONE CENTRED AND ONE EACH END WITHIN 100MM.

2. FEED LED STRIP TAILS (OR CABLE) THROUGH HOLE IN EXTRUSION. DO NOT INSTALL LED STRIP AT THIS POINT.

3. SCREW EXTRUSIONS TO MOUNTING SURFACE USING 6GX25 SELF-TAPPING SCREWS (OR SIMILAR). EITHER COUNTERSUNK OR PAN-HEAD SCREWS MAY BE USED. DO NOT OVER-TIGHTEN SCREWS OR EXTRUSION MAY DEFORM.

4. MAKE ELECTRICAL CONNECTION: CONNECT LED STRIP TAILS TO LED DRIVER (SEE FIG. 1 IF SUPPLIED WITH MALE/FEMALE CONNECTORS).

5. IF USING MULTIPLE LENGTHS OF EXTRUSION, SLIDE EXTRUSIONS TOGETHER ON TO JOINER OR BEND PLATE AND SECURE WITH GRUB SCREWS PROVIDED.

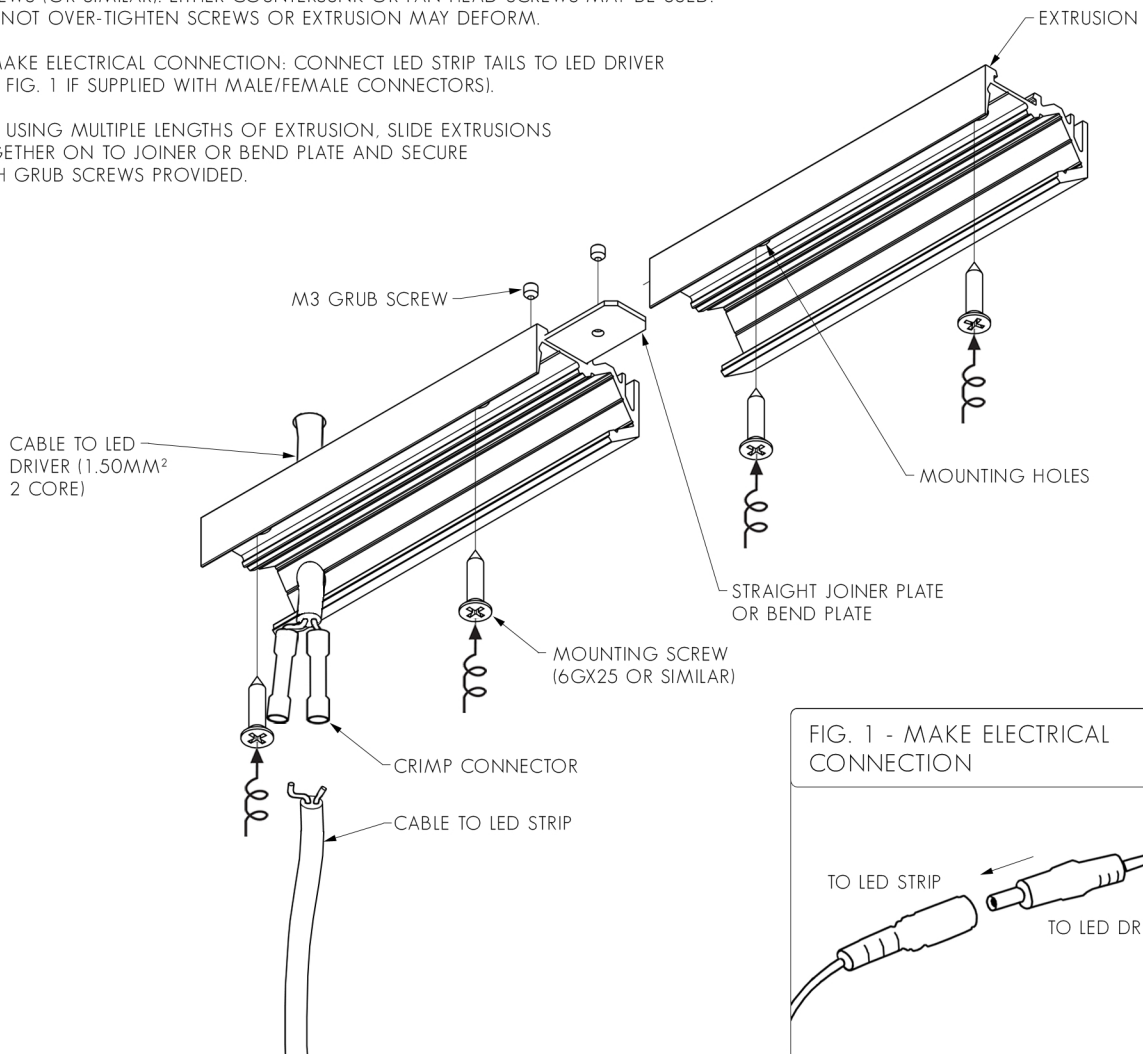

FIG. 1 - MAKE ELECTRICAL CONNECTION

3 INSTALL SCREW HEAD COVER EXTRUSION AND END CAPS

1. CLIP SCREW HEAD COVER EXTRUSION ON TO MAIN EXTRUSION. ENSURE A SECURE FIT (SEE FIG. 2).
2. SLIDE END CAPS ON TO EXTRUSION.

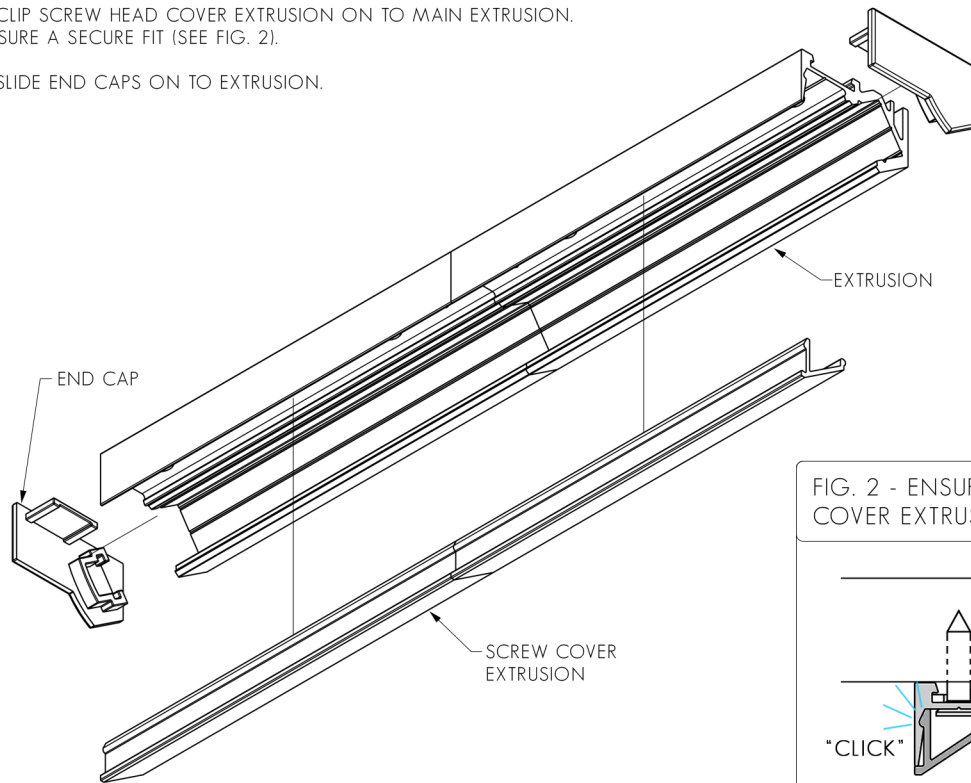
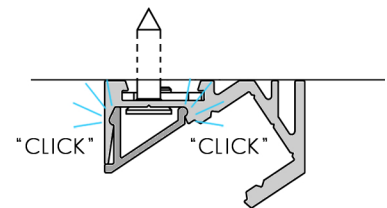

FIG. 2 - ENSURE SCREW HEAD COVER EXTRUSION IS SECURE.



4 CLEAN EXTRUSION, INSTALL LED STRIP AND DIFFUSER

1. **IMPORTANT:** BEFORE MOUNTING LED STRIP, CLEAN EXTRUSION USING AN ALCOHOL BASED CLEANER.
2. REMOVE BACKING FROM LED STRIP TO EXPOSE STICKY SURFACE. LAY LED STRIP INTO EXTRUSION, USING THE SMALL GROOVES IN THE BACK OF THE EXTRUSION AS A GUIDE. USE A DAB OF SILICON AT EACH END OF THE LED STRIP TO PREVENT ENDS FROM LIFTING OFF EXTRUSION.
3. CLIP DIFFUSER INTO EXTRUSION, ENSURING A FIRM CONNECTION (SEE FIG. 3).

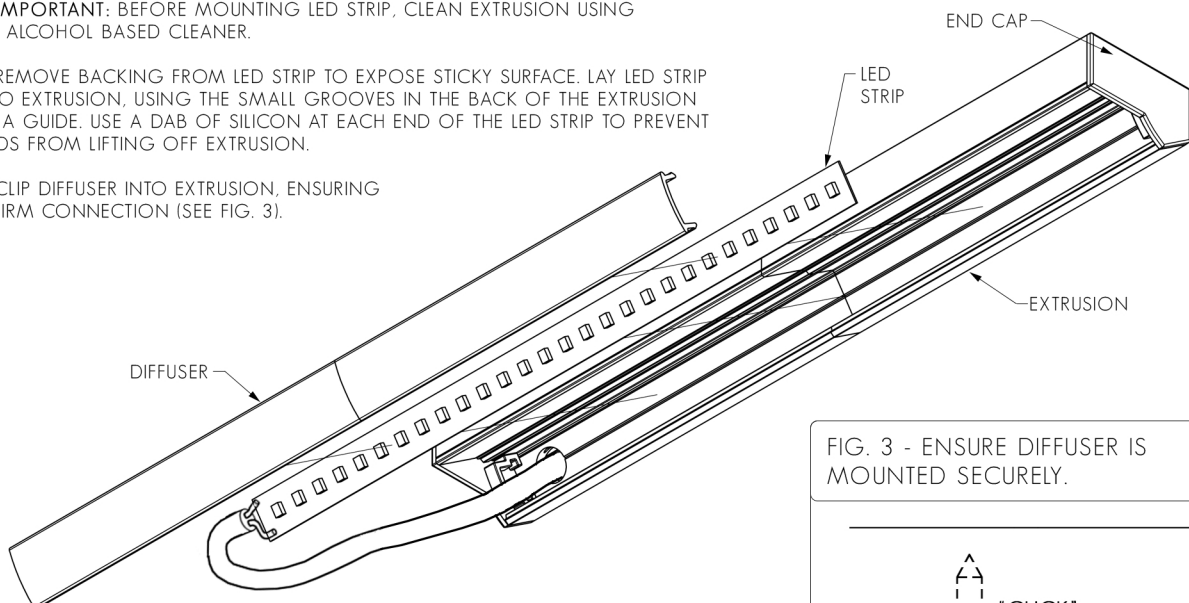

FIG. 3 - ENSURE DIFFUSER IS MOUNTED SECURELY.

